C Series Switch Mode Power Supply

Table of Contents

Safety Precautions	3
Appearance and Meaning of Safety Warnings	4
Hazard and Caution Safety Warnings	5
Introduction to C Series	8
Names of Product Parts	9
Model Number Description	10
Input and Output Terminals, Connectors, and Pin Assignments	11
Block Diagrams	15
Functional Description	16
Parallel Operation	16
Input Voltage Range, Harmonic Current, and Inrush Current	17
Input voltage range	17
Harmonic current	17
Inrush current	17
Protection Functions	17
Overcurrent protection (OCP)	17
Overvoltage protection (OVP)	17
Thermal shutdown protection	17
Alarm Functions	18
PR signal	18
LV-Alarm signal	18
Output voltage adjustable range and remote sensing	20
Output voltage adjustable range	20
Remote sensing	20
Remote on/off control	21
Installation and De-Installation	22
DC module connection	22
DC module disconnection	23
Base power unit installation	24
Derating	25
Mounting Dimensions – C300	26
Mounting Dimensions – C450	27
Mounting Dimensions – C650	28

This paper is prepared as of December 2016 and subject to change without notice.

Safety Precautions





Be sure to observe the precautions explained below.





1. Be sure to read this complete document and the detailed specifications of the individual products in the product series before using the product.
2. The products should be handled only by persons who have competent electrical knowledge.
3. The products are DC stabilized power supplies with special structures created for mounting on devices, please implement safety design of the devices under customers' responsibility not to endanger human life, health and property due to malfunction and/or failures of the products when using.
4. Although Sanken strives to improve the quality and the reliability of the products, please implement safety designs that comply or exceed all industry standards and all of the regulatory requirements of the jurisdictions where the products will be used. Safety designs for use of the products are the responsibility of the customer or user. The customer or user has the responsibility not to endanger human life or health, or to damage property due to malfunction and/or failures of the products when using them.
5. Sanken products listed in this publication are NOT intended to use for equipment and applications where extremely high reliability is required such as aerospace equipment, nuclear power-control stations and medical equipment, for which there is enhanced risk that the products could endanger human life or health due to malfunction and/or failures of the products (Classified III or above per GHTF, Global Harmonization Task Force, Medical Equipment Class) Sanken assumes no responsibility for any damage to any customer and/or any third party due to use of Sanken products for the such use.
6. When considering use of the products for the following equipment and applications, for which there is the risk that may heavily endanger human life or affect maintenance of public function, be sure to secure sufficient fail-safe function at customers' devices by means of multiplexing of systems and other method.
 - Electric trains and other conveyances such as elevators, etc. that could result in personal injury
 - Vehicles and vessels, etc. that could be affected by vibration or shock
 - Traffic systems, etc. that could exert an important influence on society and the public
 - Any other applications and equipment similar to those mentioned above.
7. Be sure to observe the items below:
 - Do not disassemble, repair, or modify these products.
 - Do not touch inside of the products because of high voltage.
 - Use the products within the specified input voltage, frequency, output voltage, and output current ranges.
 - Be sure to observe designated ambient environment conditions, such as ambient temperature and relative humidity.
 - Each product model has a designated method for installation and mounting. Observe installation and mounting instructions.

Appearance and Meaning of Safety Warnings

In this document, the levels of safety warnings are divided into two categories, Hazard and Caution.



 Hazard	Disregarding a Hazard display and incorrectly using the product could result in death and/or serious injury.
 Caution	Disregarding a Caution display and incorrectly using the product could result in personal injury and/or physical damage.

Be sure to observe the safety precautions indicated on the product and in documentation by symbols and text. The general meaning of symbols is as follows:





	Prohibited action
	Strong warning
	Electric shock hazard
	Fire hazard

Hazard and Caution Safety Warnings











General Cautionary Notices

 Hazard	
	<ul style="list-style-type: none"> • Shock hazard • Never take off the cover. • There is a high voltage circuit inside and touching it mistakenly could result in death and/or serious injury.
	<ul style="list-style-type: none"> • Fire hazard • If any abnormal odor or abnormal noise, or smoking or ignition arises in the product, immediately turn off the product and cut the power input to the product by opening an external circuit breaker or other means. • Please contact the vendor from which the product was purchased and/or Sanken. • <u>In case of fire, use a fire extinguisher of a powder/ABC type approved for use on electrical fires.</u> <p><u>Note: Never use water.</u></p>



Handling of Base Power Unit

 Caution	
	<ul style="list-style-type: none"> • Never install devices other than the designated Sanken DC modules into open slots in the products. • Never insert your hand into open slots.
	<ul style="list-style-type: none"> • The ground terminal of the product should be connected to earth ground correctly. • Unless connected directly to earth ground, electric shock could result. • Ensure that the grounding wire is connected directly to earth with a thick and short wire.
	<ul style="list-style-type: none"> • Inside the base power unit is high voltage. • Never disassemble, repair, or remodel the base power unit or touch directly inside it with your hands, otherwise electric shock could result.
	<ul style="list-style-type: none"> • The base power unit installation and mounting specifications are provided. Ensure that the base power unit is installed according to the specifications. • Do not install the base power unit incorrectly.

Handling of DC Modules

 Caution	
	Observe installation and mounting directions as described in the operation manual, otherwise fire or electric shock due to failures, degradation, and so forth, could result.
	Turn the power source off and make sure that the supply of power has stopped before replacing the DC module, otherwise fire or electric shock due to failures, degradation, and so forth, could result.
	DC modules could retain residual electrical charges and have a hot temperature after operation. Do not touch them carelessly soon after powering them down, and be sure to let them cool down completely before resuming operation.
	When taking out and putting in DC modules, make sure not to touch any components on the printed circuit board (PCB), otherwise personal injury and/or damage to the products could result.
	When taking out DC modules, because connectors could be connected tightly, be careful not to cause personal injury and/or damage to the products.
	Do not take out or put in DC modules when the power supply is operating, otherwise it could cause damage to the DC modules.
	Be sure not to store DC modules on metal surfaces. If the back side of a DC modules is placed against a metal surface, it could cause damage to the DC modules.
	Make sure not to use DC module alone. When using DC modules, make sure to connect them with an appropriate base power unit.
	When a load short-circuit and/or a short-circuit at start-up arise, damage to the products could result. Before powering-up the products, please make sure to pay special attention to ensuring that no load short-circuit condition exists.













Insulating Resistance and Withstand Voltage

 Caution	
	Be sure not to conduct withstanding voltage test without inserting Sanken DC modules. When applying insulating resistance test and withstand voltage test, please consult with Sanken.

Other Precautions



Caution

	Each power supply model has a designated input/output range. Be sure to use the products within designated input/output range.
	Be sure that the total power consumption connecting with the load does not exceed the rated output capacity per each power supply. If a power supply is used under an overload condition, it could cause fire.
	Be sure to use thick wire for input/output wiring, and that it is appropriate for the input/output power. If thin wires are used, it could cause fire.
	Be sure not to use and/or store the products in temperature, humidity, and dew condensation conditions beyond the ambient environmental conditions specified in the catalog and/or operation manual, otherwise failure of the products could result.
	When the power supply is operated in dusty conditions, please apply dust proofing measures. The dust could interfere heat dissipation and cause failure and/or fire.
	When the power supply is installed, be sure to use designated screws (paying particular attention to screw length and diameter), otherwise electric shock and/or fire could result.
	The products are not intended for use in equipment that requires high reliability for sustaining human life. Be sure not to use the products for any particular application such as in nuclear reactor and/or power control systems, aerospace applications, special Medical equipment, and so forth.
	When installing the products, be sure to connect each input terminal and output terminal without fail, otherwise malfunction and damage to the products, personal injury, and fire could result.
	Be sure not to apply any external voltage to output terminals of the products, otherwise damage to the internal devices of the products could result.
	Be sure not to use and/or store the products in an environment with corrosive gases such as hydrogen sulfide, sulfur dioxide, and so forth, otherwise damage to the products could result.
	When operating the products in an environment with interference from radio waves, electric fields, or magnetic fields, the products may malfunction, which could lead to failures. Be sure not to use the products under such conditions.
	Although Sanken strives to improve the quality and the reliability of the products, the customer and user are responsible to be sure to apply safe design of their equipment before using the products.

Introduction to C Series

General Description

The C Series are flexible multi-output power supplies that enable simple combination of various modules.

Features and Benefits

- High reliability with low noise and low leakage current
- Medical and information equipment approval to UL60950-1, C-UL, EN60950 and EN60601-1 3rd
- Direct PFC with interleaving and AC synchronized rectification
- Higher withstand voltage and lower leakage current
- OCP, OVP and OHP, remote sensing, control, and alarm (AC power fail, fan alarm, and low output)



DC Module
(Typical)



C300



C450



C650



Names of Product Parts

Base Power Unit – Front View (with DC modules installed)

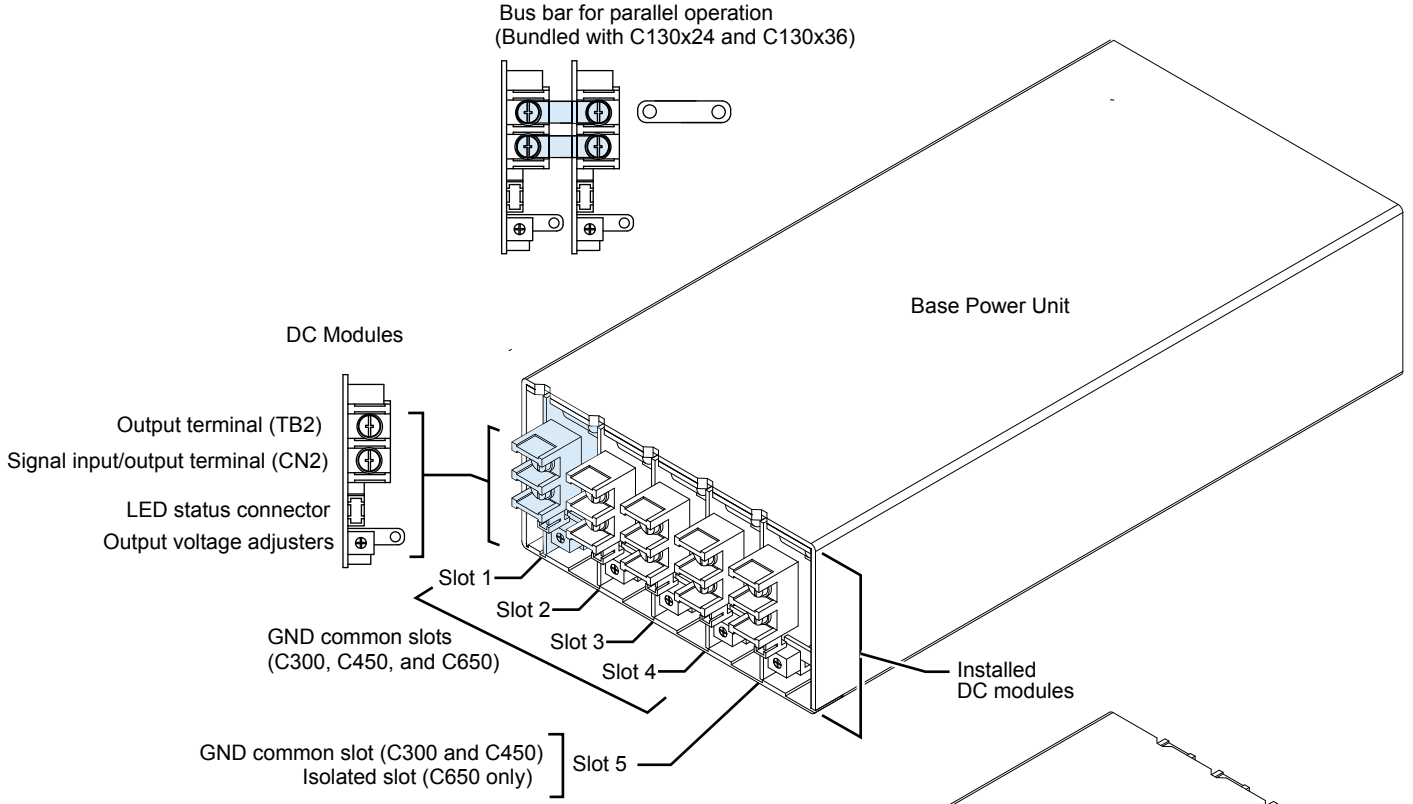

Base Power Unit – Rear View

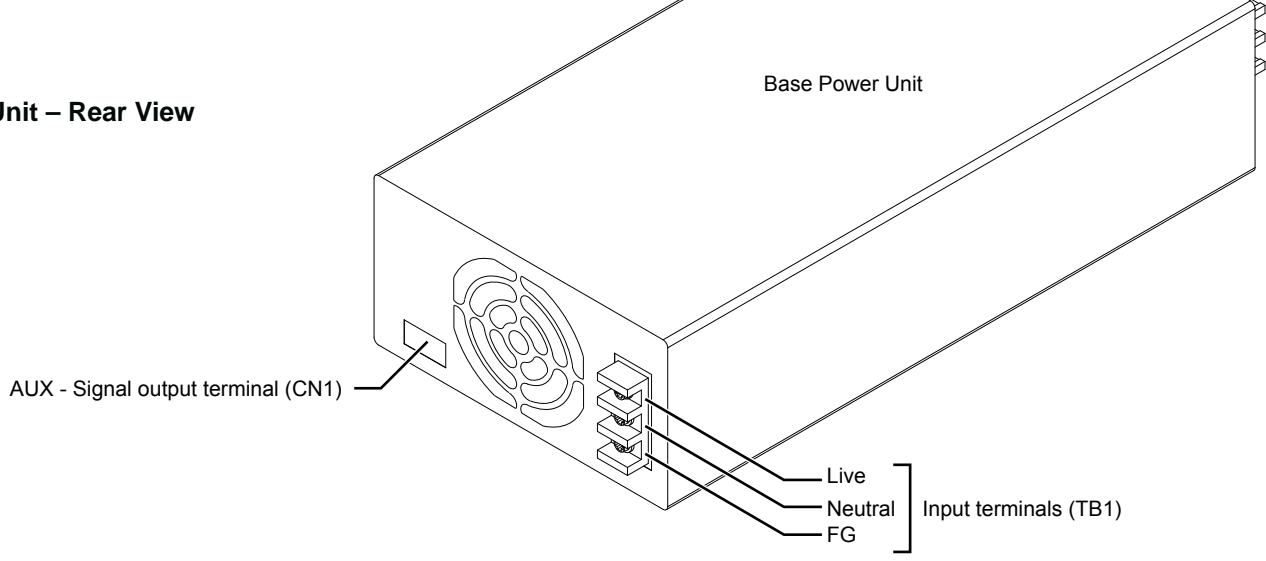

DC Module – Simplified View

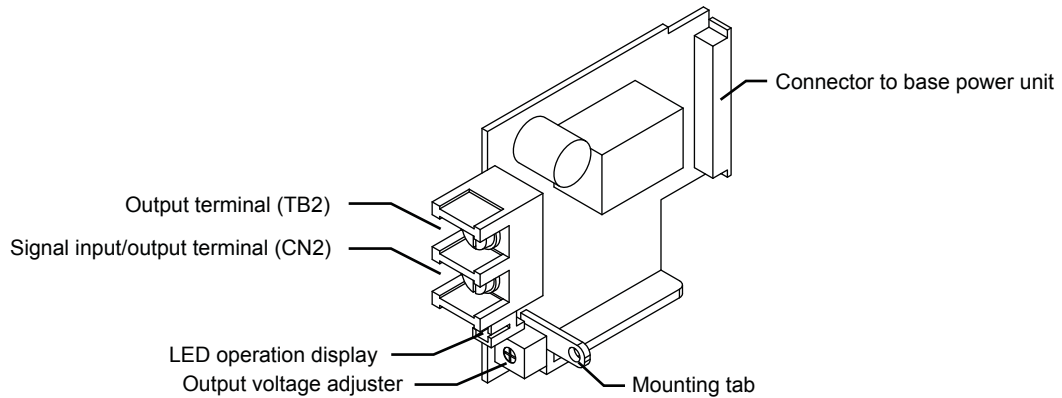

Model Number Description

Base Power Unit

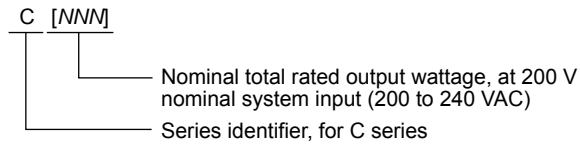

DC Module

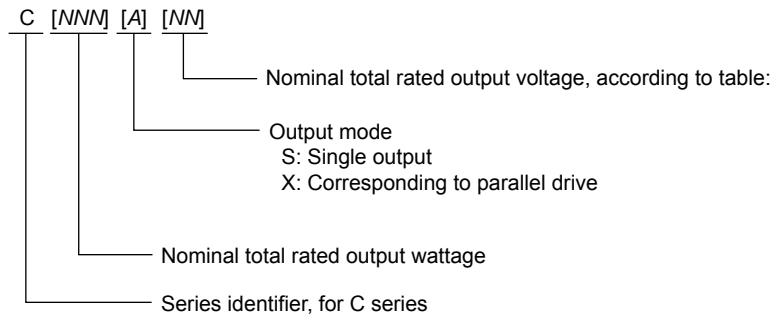

Symbol	Voltage (V)
03	3.3
05	5
12	12
15	15
24	24
36	36

Input and Output Terminals, Connectors, and Pin Assignments

Base power unit terminals, connectors, and pin assignments

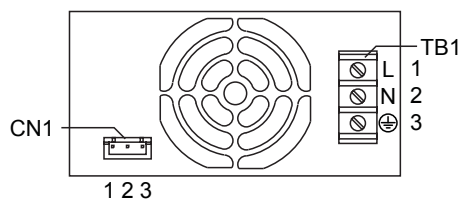

C300, C450 and C650 Power Inputs				
Identification Symbol	Connector Model	Pin Assignments		
		Pin Number	Name	Note
TB1	UF2028AX (Fujicon)	1	AC (Live)	AC input
		2	AC (Neutral)	AC input
		3	FG	FG connection
	Screws			
	Size	Recommended Fastening Torque		
	M4	1.2 N•m (12.3 kgf•cm)		

C300, C450 Auxiliary Terminals				
Identification Symbol	Connector Model	Pin Assignments		
		Pin Number	Name	Note
CN1	S3B-XH-A (JST)	1	GND	Auxiliary output GND
		2	PR	Alarm signal; active high at alarm operation
		3	AUX	Auxiliary output; for remote on/off
	Housing			
	XHP-3 (JST)	Housing		
	SXH-001T-P0.6 (JST)	Contact		

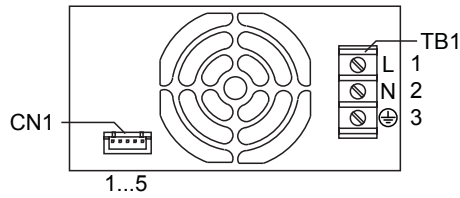

C650 Auxiliary Terminals					
Identification Symbol	Connector Model	Pin Assignments			
		Pin Number	Name	Note	
CN1	S5B-XH-A (JST)	1	AUX1	Auxiliary output1; for remote on/off of GND common slots	
		2	GND1	Auxiliary output GND 1	
		3	PR	Alarm signal; active high at alarm operation	
		4	GND2	Auxiliary output GND 2	
		5	AUX2	Auxiliary output 2; for isolated slot	
	Housing				
	XHP-5 (JST)	Housing			
SXH-001T-P0.6 (JST)	Contact				

DC module terminals, connectors, and pin assignments

Single output DC modules

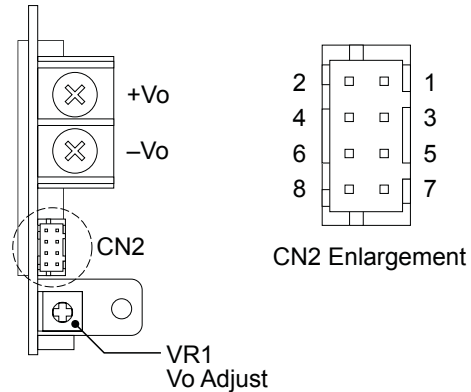

Single Output DC Module Power Terminals				
Identification Symbol	Connector Model	Pin Assignments		
		Pin Number	Name	Note
TB2	UF2028AX (Fujicon)	1	+Vo	Output voltage (+)
		2	-Vo	Output voltage (-)
	Screws			
	Size	Recommended Fastening Torque		
	M4	1.2 N•m (12.3 kgf•cm)		

Single Output DC Module Signal Terminals					
Identification Symbol	Connector Model	Pin Assignments			
		Pin Number	Name	Note	
CN2	S8B-PHDSS (JST)	1	+Remote On/Off	Remote on/off	
		2	-Remote On/Off	Remote on/off (GND)	
		3	+M	Remote sensing auxiliary terminal 1 (Only for C150S)	
		4	-M	Remote sensing auxiliary terminal 2 (Only for C150S)	
		5	LV-Alarm+	LV alarm output	
		6	LV-Alarm-	LV alarm output (GND)	
		7	+Remote Sense	Remote sensing, Vo side (Only for C150S)	
		8	-Remote Sense	Remote sensing, GND side (Only for C150S)	
	Housing				
		PHDR-08VS (JST)	Housing		
	SPHD-001T-P0.5 SPHD-002T-P0.5 (JST)	Contact			

Block Diagrams

C300 series

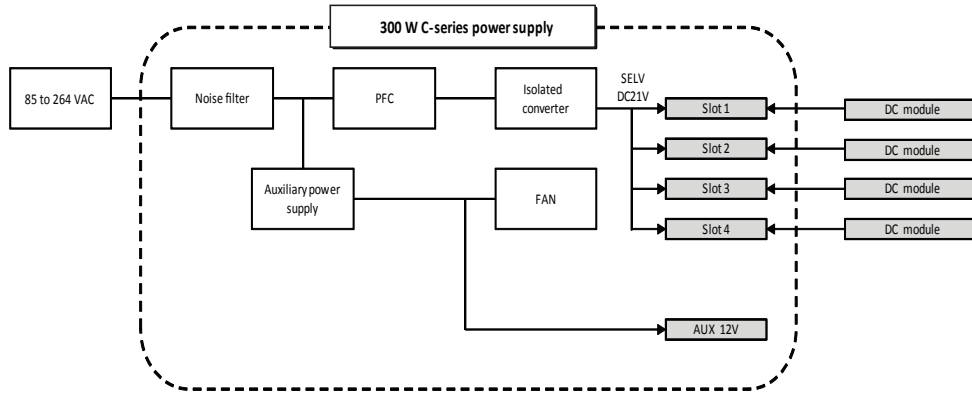

C450 series

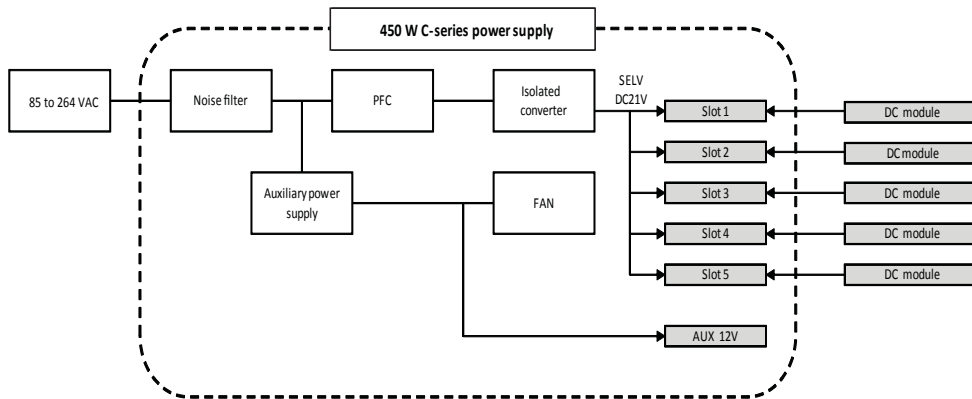

C650 series

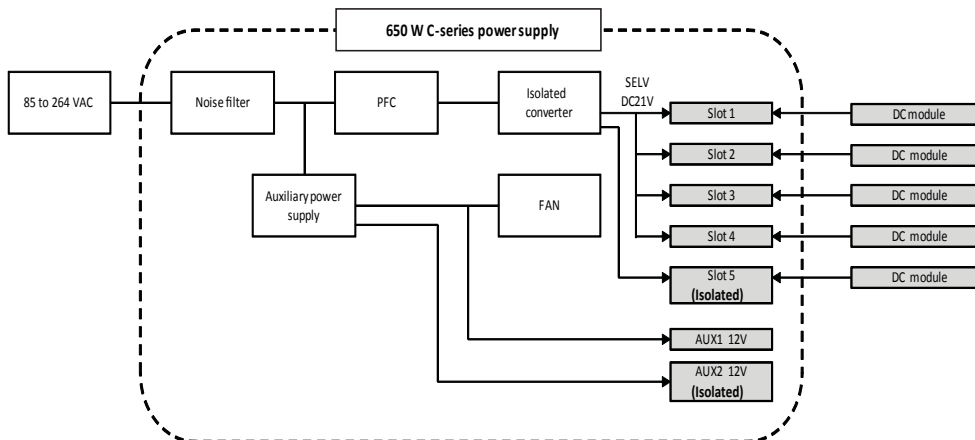

Functional Description

Parallel Operation

DC modules capable of parallel operation are available as the C130X24 C130X36 model. Be sure to pay attention to following notes when operating in parallel using the DC modules.

1. When using the DC modules with adjusted output voltage, all DC modules to be connected in parallel must be adjusted independently. When adjusting using the output adjuster, ensure there are no bus bars bridging between different DC modules before rotating the output adjuster. Upon completion of adjustment of the output voltage, then please install the bus bars.

2. When connecting the output terminals, be sure to connect only terminals with the same electrical polarity characteristics to the same bus bar.

3. When installing DC modules in parallel operation configuration in a base power unit, be sure to use only slots that are designed for parallel operation in the base power unit, as per the following table:

Slots corresponding to parallel operation

	C300	C450	C650
Slot 1	○	○	○
Slot 2	○	○	○
Slot 3	○	○	○
Slot 4	○	○	○
Slot 5		○	×

○: Compatible with parallel operation
 ×: Not compatible with parallel operation

4. When using the products with a dynamic load, be sure to apply full evaluation and testing in the application before using.

	CAUTION: The products are not compatible with series operation. Be sure not to use the products in a series configuration.
------------------------------------------------------------------------------------	-----------------------------------------------------------------------------------------------------------------------------------

Input Voltage Range, Harmonic Current, and Inrush Current

Input voltage range

The input voltage range of a base power unit is 85 to 264 VAC. If other than specified input voltages are applied, it could cause the products to fail to operate within the specifications and/or cause permanent failure of the products.

Harmonic current

A harmonic current suppression circuit (active filter) is incorporated into each base power unit, and harmonic current is suppressed in all load conditions from no load to full load. The input voltage range at which the harmonic current suppression circuit activates is between 85 and 264 VAC.

Inrush current

If a switch is used for controlling input, be sure to select a switch that can withstand the expected inrush current. If the AC supply is being switched off and on again, before reapplying power wait until the internal cooling fan has stopped moving, otherwise a large current could flow after release of the inrush preventive circuit.

Protection Functions

Overcurrent protection (OCP)

Each DC module has an isolated overcurrent protection circuit incorporated into it. When OCP is activated, it shuts down the respective DC module. If output is stopped due to an overcurrent condition, be sure to evaluate the load condition and remove the causes of overcurrent before reapply AC either by remote on/off or by input of the base power unit.



CAUTION: OCP does not necessarily guarantee complete protection against any short in the output circuit. Be sure not to short the output when using the products.



CAUTION: Regardless of the OCP range, be sure not to exceed total rated output current range or rated output power of the products.

Overvoltage protection (OVP)

Each DC module has an isolated overvoltage protection circuit incorporated into it. When OVP is activated, it shuts down all output. If output is stopped due to an overvoltage condition, be sure to shut off the input and delay reapplying the AC supply until more than 30 seconds after removal of the causes of the overvoltage condition.

Thermal shutdown protection

Each base power unit has a thermal shutdown protection circuit incorporated. The circuit is activated when the following abnormalities occur:

- When the airflow volume of the internal fan is lowered and/or stopped, the internal temperature rises.
- When the base power unit is used for a long time in conditions exceeding the total rated power.
- When the base power unit is used in an ambient temperature exceeding specified temperature in the specifications.

When thermal shutdown is activated, it shuts down all output. Be sure to shut off the AC supply and remove the causes of the overheating, as well as delay long enough for the products to cool to normal temperatures, before reapplying the AC supply. If the application requires that the product be used continuously, be sure to apply thorough investigation of the causes and countermeasures for overheating before using the product.

Alarm Functions

PR signal

This alarm is incorporated into each base power unit. The PR terminal is set high when input voltage into the main body of the base power unit is lowered below specification and/or the internal fan is stopped.

LV-Alarm signal

This alarm is incorporated into each DC module. The LV-Alarm+ terminal is set high when the output of the DC module is lowered below specification and/or is stopped.

Alarm Specifications

Alarm Signal	Operating Condition	Alarm Signal State
PR	Good	Set low ($\leq 0.8 \text{ V}$ and $\leq 8 \text{ mA}$)
	Bad	Set high (2 to 35 V, or open)
LV	Good	Set low ($\leq 0.8 \text{ V}$ and $\leq 20 \text{ mA}$)
	Bad	Set high (2 to 35 V, or open)

PR terminal internal circuit

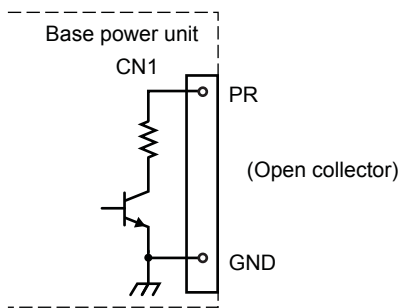

LV-Alarm terminal internal circuit

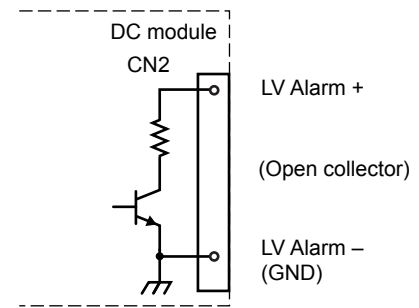

Alarm Timing Diagram

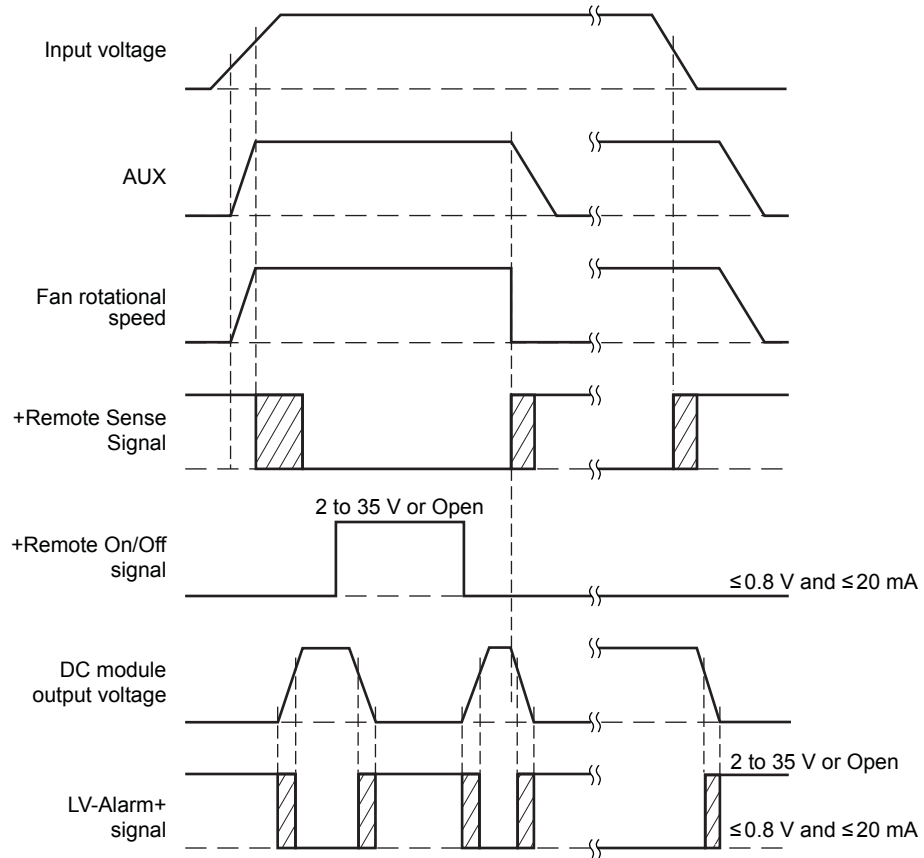

Output voltage adjustable range and remote sensing

Output voltage adjustable range

Each DC module has either one or two output voltage adjusters. Rotate the adjuster clockwise to increase the output voltage and counterclockwise to decrease the output voltage. When adjusting the output voltage, be sure not to exceed either the rated output power of the system, or the rated output current of the module. The output voltage adjustable range varies for each DC module. Please ascertain the specification of each DC module before using.

Remote sensing

Some DC modules incorporate remote sensing function. Remote sensing functions allow the system to compensate for voltage reduction due to output wiring. The range of voltage compensation available varies according to DC module, as shown in the table at right.

When using remote sensing, be sure to conduct a thorough evaluation and adjustment of the application system, based on the remote sensing connection example shown.

Be sure to pay attention to following notes when using the remote sensing function:

- Be sure to use thick wire, with a sufficient current capacity margin above the maximum output current for wiring from power supply to the load. Set the line drop to the compensated voltage or below.
- Oscillating waveforms and/or fluctuations of output voltage could arise due to wiring and load impedance. Be sure to apply a thorough evaluation before using the products.

Remote Sensing Voltage Compensation

DC Module Type	Voltage Compensation Range
C150S03, C150S05, C150S12, C150S15	0.15 V and below
C150S24	0.30 V and below

NOTE: Any DC module not listed in this table is not compatible with remote sensing.

Remote sensing connection example

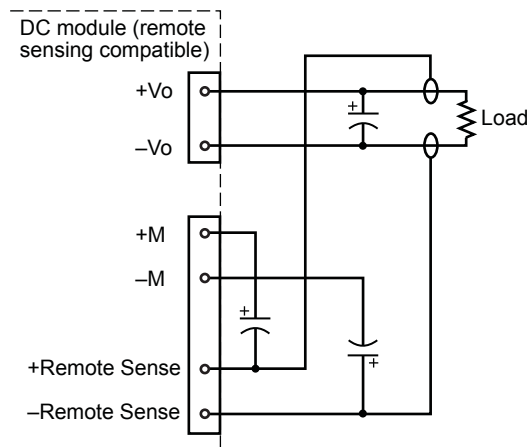

CAUTION: When a bad connection (for example, caused by a loose screw) of a load wire arises, the load current flows into the remote sensing wire and it could cause damage to the power supply due to overheating. Be sure to pay attention when connecting wires.

Remote on/off control

Each DC module has a remote on/off capability incorporated. This function allows the output voltage to be switched on and off by an external signal input to the DC module corresponding Remote On/Off terminal.

By applying a voltage in the range of 10 to 27 V to the Remote On/Off + terminal, the output of the corresponding DC module is stopped. Please note that the fan inside of the main body of the base power unit does not stop as a direct result of the output of a DC module being stopped by the Remote On/Off function.

	CAUTION: If a voltage out of specification is applied, it could cause malfunction and/or damage to the power supply. Be sure to apply specified voltage.
-----------------------------------------------------------------------------------	-----------------------------------------------------------------------------------------------------------------------------------------------------------------

A remote on/off signal effects each DC module individually and cannot be used to shut all output off via the corresponding base power unit. All or some of the GND common slots in a DC module can be stopped and started simultaneously by connecting each remote on/off circuit in parallel.

	NOTE: The GND common slots (and the isolated slot on the C650) should not be used to stop the base power unit.
-------------------------------------------------------------------------------------	-----------------------------------------------------------------------------------------------------------------------

The AUX signal output terminals (in base power unit connector CN1) can be used for remote on/off control.

Model C650 has two such terminals, AUX1 and AUX2. Use AUX1 for DC module on/off control by connecting it to the GND common slots (slots 1 to 4) and use AUX2 for DC module on/off control by connecting it to the isolated slot (slot 5).

	CAUTION: If a combination of connections is used that is different from the combination specified above, it could cause malfunction and/or damage to the products.
-----------------------------------------------------------------------------------	---------------------------------------------------------------------------------------------------------------------------------------------------------------------------

The specification for operation of the remote on/off function is shown in the table at right, when using the connection examples shown.

Remote On/Off Signal Specification

Remote On/Off Terminal Input Signal	DC Module Output State
Low (0 to 0.5 V) or open	Output on
High (10 to 27 V)	Output off

Remote On/Off connection example using switch

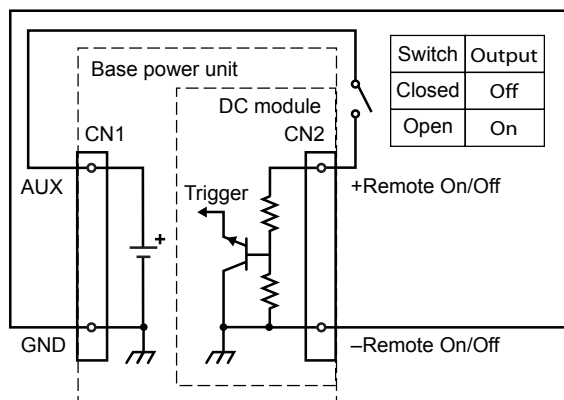

Remote On/Off connection example using transistor

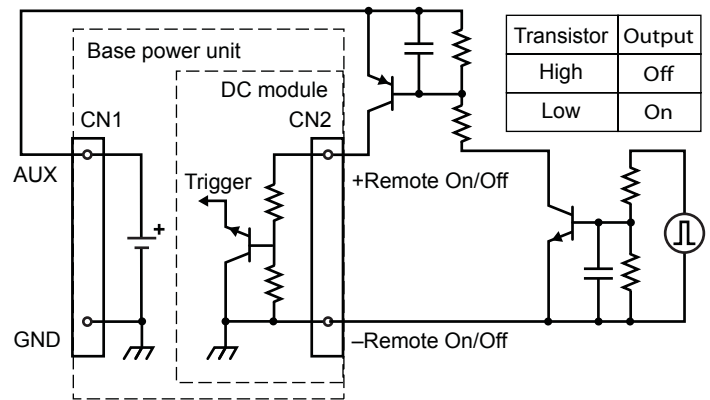

Installation and De-Installation

DC module connection

To install a DC module into a base power unit, perform the following steps:

1. Confirm that the internal fan of the base power unit is stopped.
2. Confirm that input TB1 (AC) is shut off.
3. Align the DC module so that the mounting tab is on the bottom side and to the right.
4. Align the top and bottom of the DC module with the guide slots of the base power unit, and then slide the DC module slowly along the slots until the rear connector seats in the mating connector of the base power unit.
5. Insert an M3 × 10 screw (provided with the base power unit) through the DC module mounting tab hole, and using 0.5 N•m (5.1 kgf•cm) of torque, tighten the screw into the mounting tab on the front of the base power unit.
6. Connect the terminals of the DC module and perform the necessary tests described in this document before using the assembly.

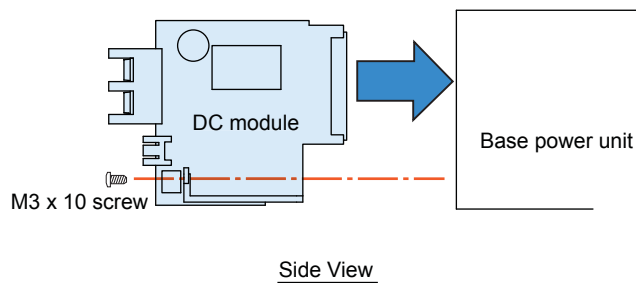
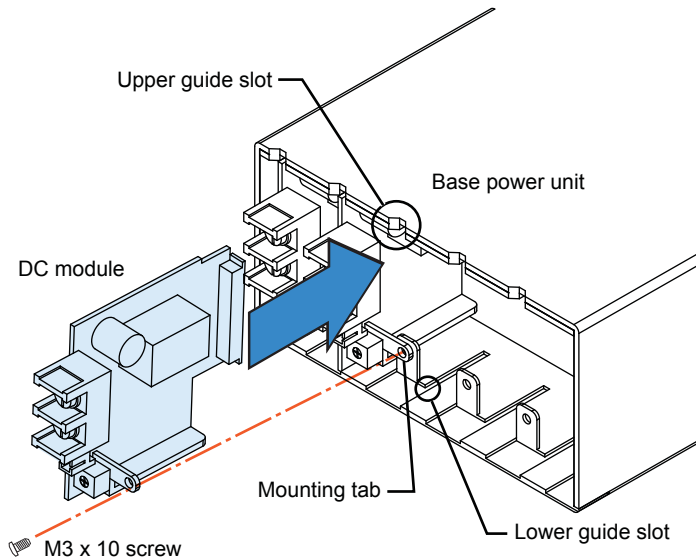

	<p>CAUTION: Be sure not to install the DC module while the base power unit is activated, otherwise personal injury and/or damage to the products could occur.</p>
	<p>CAUTION: Be sure not to damage any parts mounted on the DC module when inserting the DC module.</p>

DC module disconnection

To remove a DC module from a base power unit, perform the following steps:

1. Confirm that input TB1 (AC) is shut off.
2. Confirm that the internal fan of the base power unit is stopped.
3. Wait until the unit has cooled to room temperature.
4. Remove the screw fastening the DC module to the base power unit.
5. At the top of the DC module, gently insert a thin screwdriver between the terminal base on the DC module, and the top side of the base power unit cover.
6. Using the edge of the base power unit cover as a fulcrum, gently rotate the screwdriver handle toward the front of the base power unit, prying the DC module out of the electrical connector inside the base power unit until the DC module unseats.
7. Using gentle finger pressure, grasp the DC module and slowly pull it out of the base power unit.
8. Retest and restart the base power unit as required.

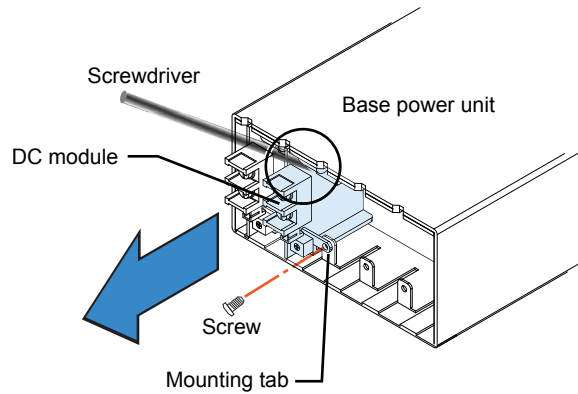

!	CAUTION: Be sure not to pull out the DC module while base power unit is activated and ensure that the AC input is shut off before pulling the DC module out, otherwise personal injury and/or damage to the products could occur.
!	CAUTION: The DC module may have a high temperature after the DC module is stopped. Be sure to allow the DC module to cool down before touching it.
!	CAUTION: Be sure not to damage any parts mounted on the DC module when pulling out the DC module.

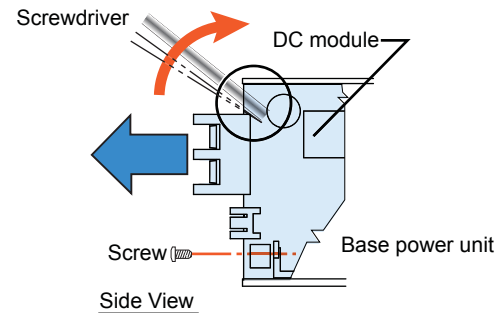

Base power unit installation

Adequate airflow is mandatory to allow the fan inside the base power unit to cool the unit and the DC modules. If the cooling effect of the fan is insufficient, output could stop.

- Ensure there is at least 50 mm of free airspace clearance both at the input side of base power unit and at the output side of the DC modules for airflow. See illustrations below for recommendations.
- When attaching the base power unit to a rack by screws, be sure to use M4 screws and keep the insertion length within 3.5 mm from surface of the base power unit case in order to maintain

insulation clearance distance to internal parts. Use M4 screws (JIS B 0205 or equivalent) with 1.2 N•m (12.3 kgf•cm) torque.

- If the product is used in a dusty environment, an air filter may be required. In such a case, the filter may affect ventilation efficiency and weaken the cooling effect of the fan, causing output to stop. Therefore derating is required for this case. Please consult with Sanken for the details.
- If the fan stops and/or the rotational speed of the fan gets lowered, the product may stop due to thermal protection. Life expectancy of the fan varies depending on usage conditions, therefore regular inspections of the fan are required for improved reliability. Please consult with Sanken for the details.

Mounting orientations for normal installations

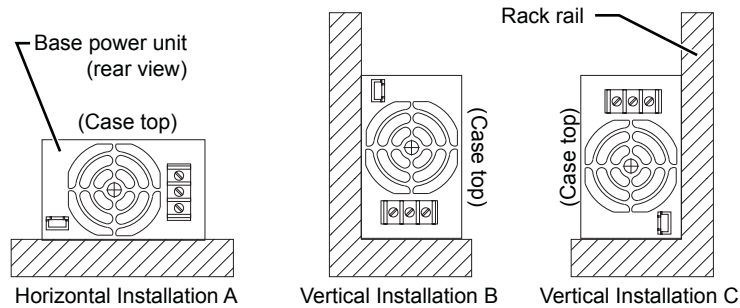

Ventilation requirements

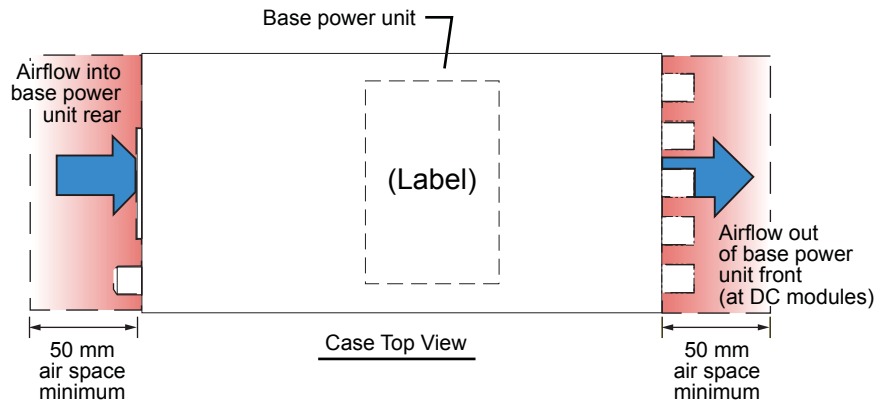

CAUTION: Do not allow screws to penetrate more than 3.5 mm into the base power unit case

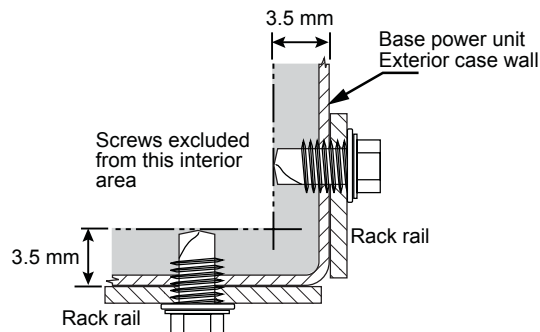

Derating

Derating is applied to the base power unit and each DC module independently. To prevent the load factor from being truncated due to the derating, make sure the base power unit and each DC module are used within specification, considering both derating of total rated power of base power unit and maximum rated power of each DC module.

The derating characteristic of the products at various ambient temperatures is shown in the chart below. This characteristic applies to both the base power unit and each DC module. Make sure to include both when calculating the total derating.

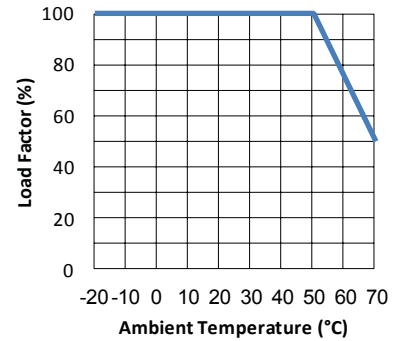

Derating characteristic versus ambient temperature

Mounting Dimensions – C300

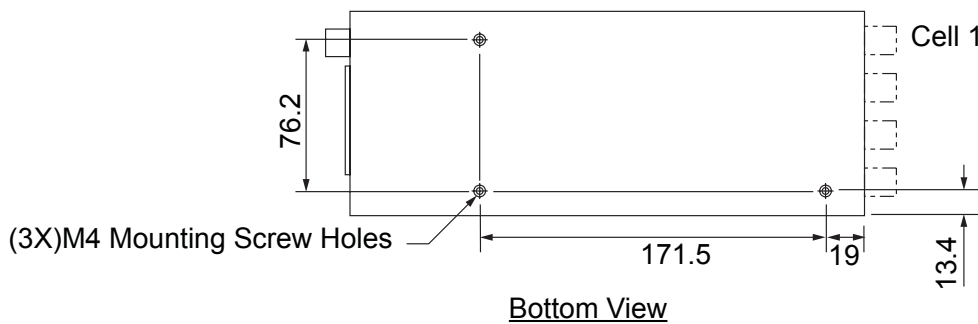
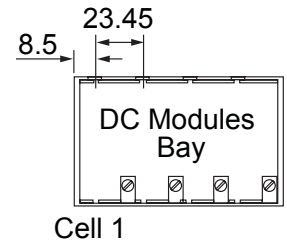
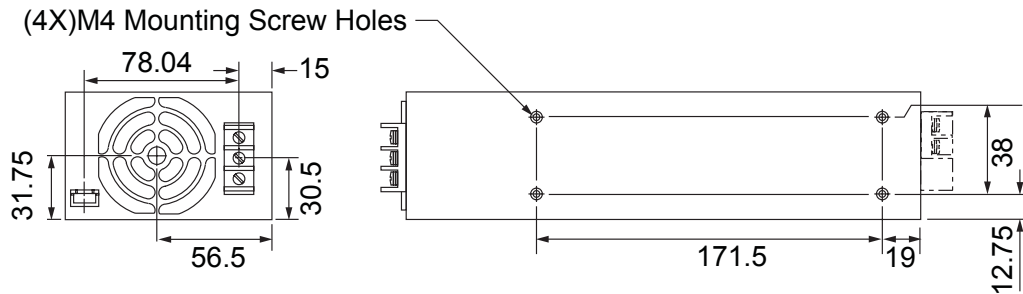
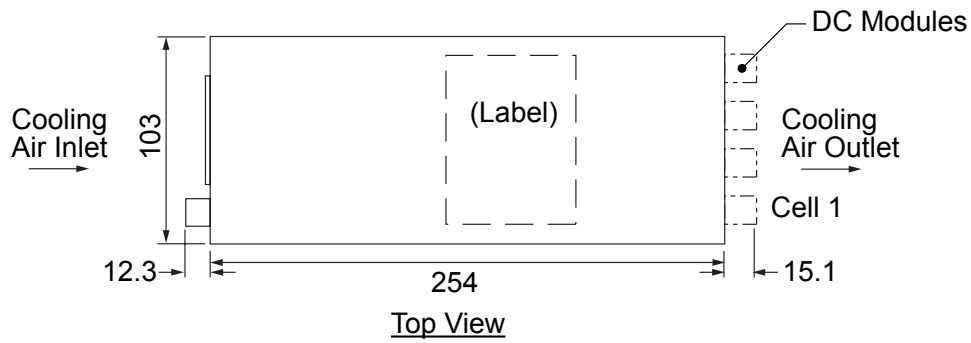
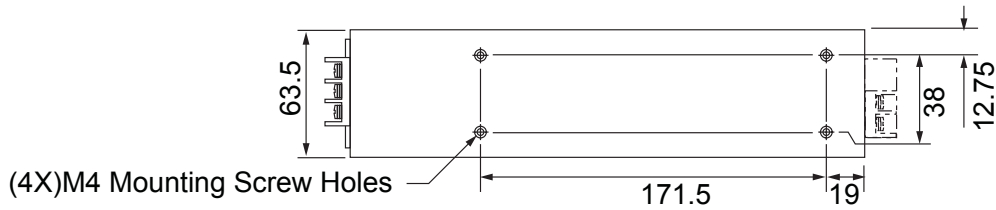

Dimensions in mm

Mounting Dimensions – C450

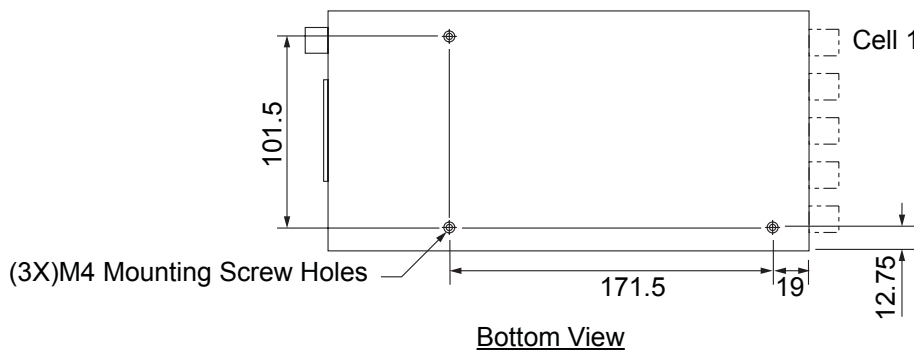
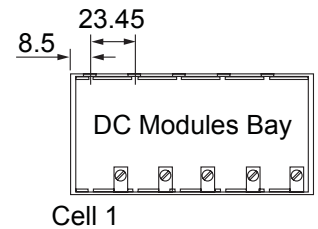
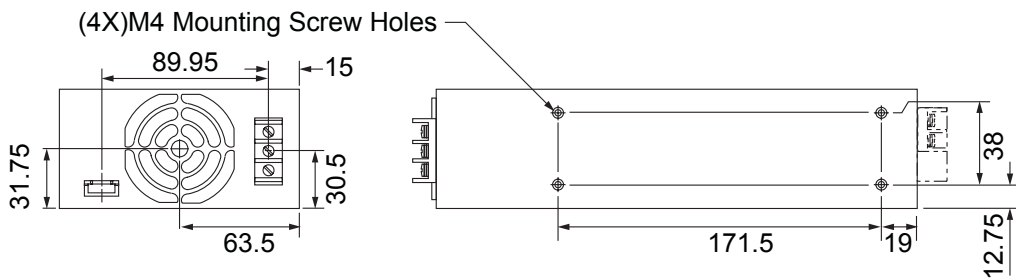
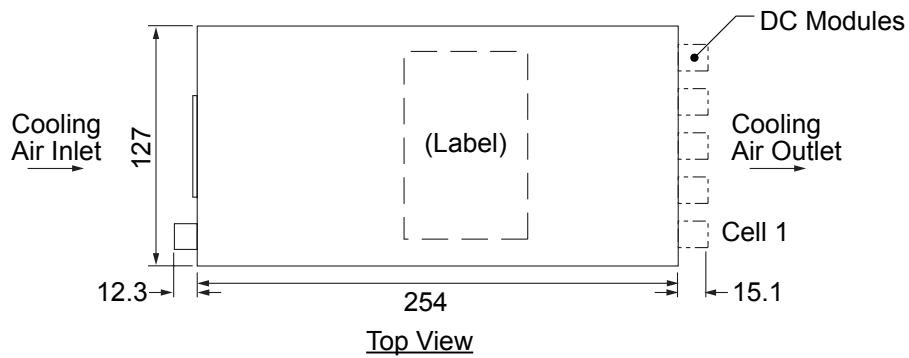
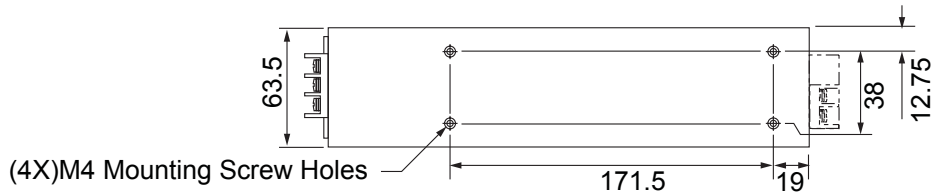

Dimensions in mm

Mounting Dimensions – C650

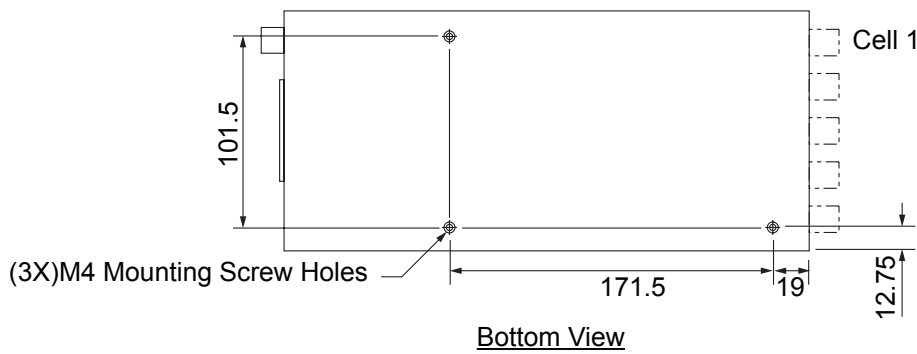
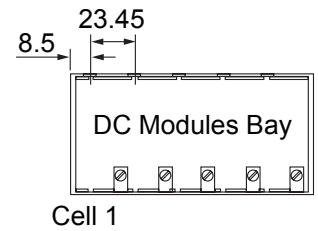
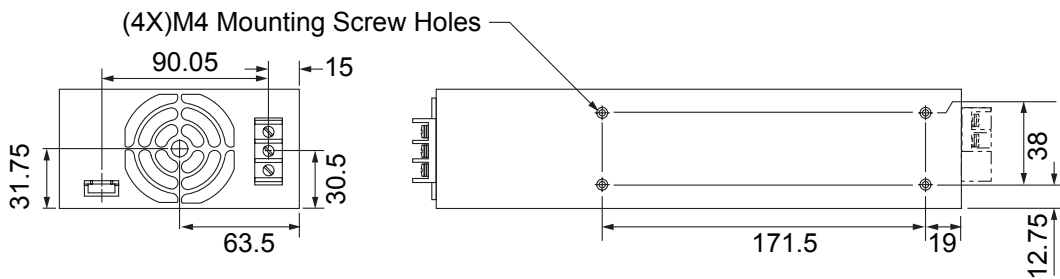
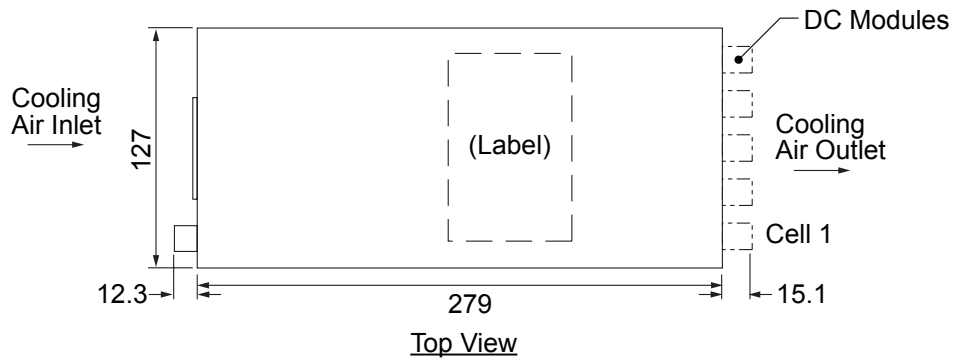
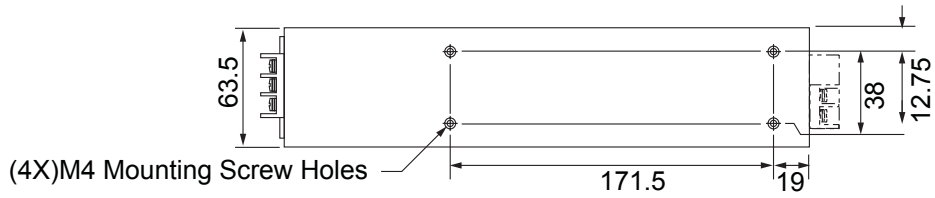

Dimensions in mm

Sanken reserves the right to make, from time to time, such departures from the detail specifications as may be required to permit improvements in the performance, reliability, or manufacturability of its products. Therefore, the user is cautioned to verify that the information in this publication is current before placing any order.

When using the products described herein, the applicability and suitability of such products for the intended purpose shall be reviewed at the users' responsibility.

Although Sanken undertakes to enhance the quality and reliability of its products, the occurrence of failure and defect of semiconductor products at a certain rate is inevitable.

Users of Sanken products are requested to take, at their own risk, preventative measures including safety design of the equipment or systems against any possible injury, death, fires or damages to society due to device failure or malfunction.

Sanken products listed in this publication are designed and intended for use as components in general-purpose electronic equipment or apparatus (home appliances, office equipment, telecommunication equipment, measuring equipment, etc.). Their use in any application requiring radiation hardness assurance (e.g., aerospace equipment) is not supported.

When considering the use of Sanken products in applications where higher reliability is required (transportation equipment and its control systems or equipment, fire- or burglar-alarm systems, various safety devices, etc.), contact a company sales representative to discuss and obtain written confirmation of your specifications.

The use of Sanken products without the written consent of Sanken in applications where extremely high reliability is required (aerospace equipment, nuclear power-control stations, life-support systems, etc.) is strictly prohibited.

The information included herein is believed to be accurate and reliable. Application and operation examples described in this publication are given for reference only and Sanken assumes no responsibility for any infringement of industrial property rights, intellectual property rights, or any other rights of Sanken or any third party that may result from its use. The contents in this document must not be transcribed or copied without Sanken's written consent.